

ZINTRA BEAMS

CLOSED RAFTER

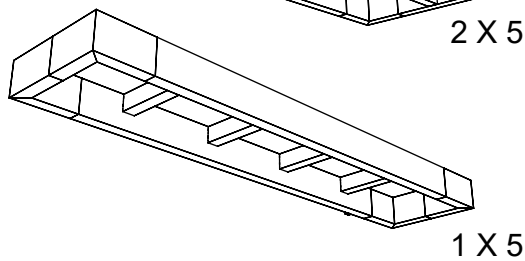
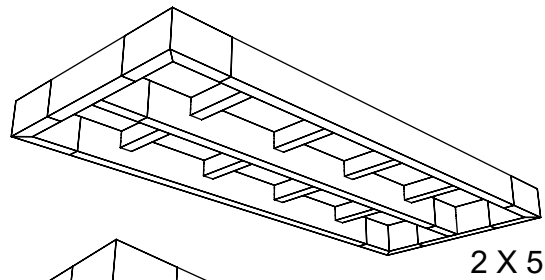
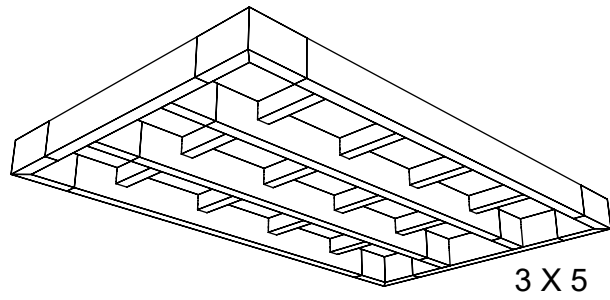
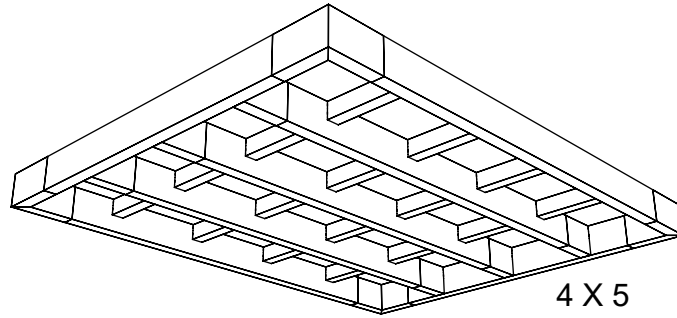
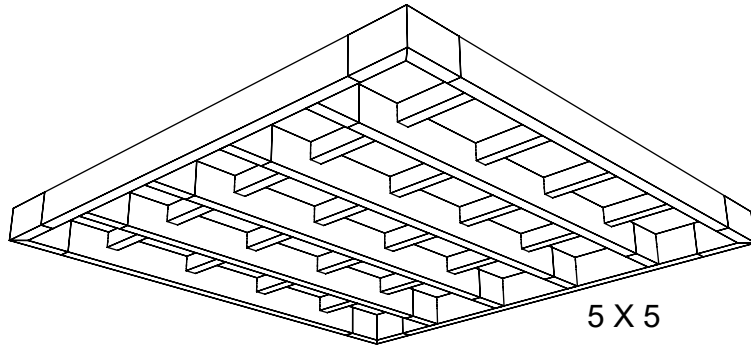

PARTS AND HARDWARE

FOR A TYPICAL ASSEMBLY

CLOSED RAFTER VERSION / QTY

8in MAIN BEAMS (96in / 72in / 48in / 24in)

5 X 5 4 X 5 3 X 5 2 X 5 1 X 5

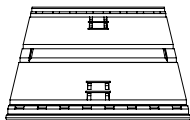
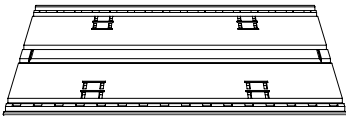
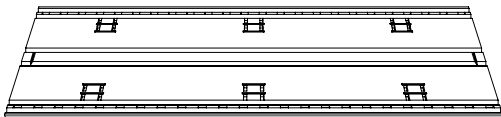
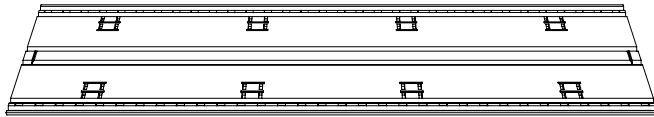

4in CONNECTING BEAM



8in EXTENTION BEAM



8in CORNER BEAM

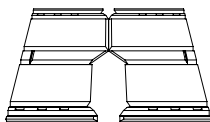

8in BEAM CONNECTOR

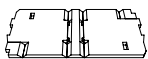

BEAMS CLIP



x8	x5	x4	x3	x2
	x2			
		x2		
			x2	
x20	x14	x12	x8	x4
x8	x6	x4	x2	
x4	x4	x4	x4	x4
x16	x14	x12	x10	x6
x104	x86	x68	x48	x28

STEP 1

BEAMS ASSEMBLY

ASSEMBLE INDIVIDUALS PARTS AS PER PURCHASED PACKAGE.

FOLD 8IN MAIN BEAM AND SECURE IT BY INSERTING BEAMS CLIPS INTO PRE-CUT RECTANGULAR HOLES.

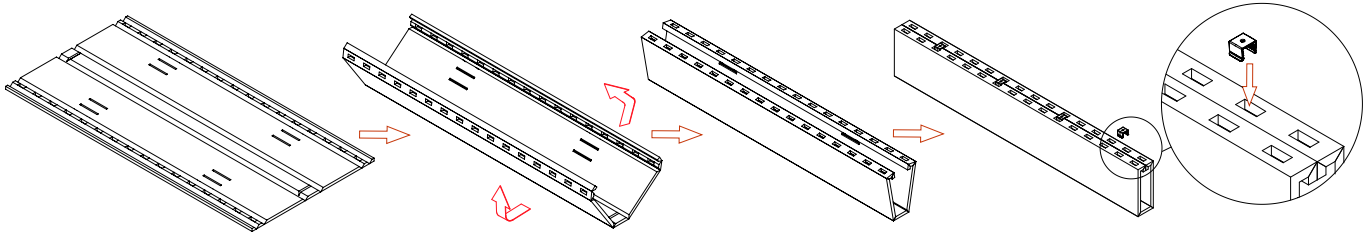

*BEAMS CLIPS QTY FOR 8IN MAIN BEAMS:

96IN BEAM - x6; 72IN BEAM - x5; 48IN BEAM - x4; 24IN BEAM - x2.

*IMPORTANT: DO NOT INSERT CLIPS INTO FIRST AND LAST HOLES OF THE MAIN BEAM

FOLD 4IN CONNECTING BEAM AND SECURE IT BY INSERTING BEAMS CLIPS INTO PRE-CUT RECTANGULAR HOLES.

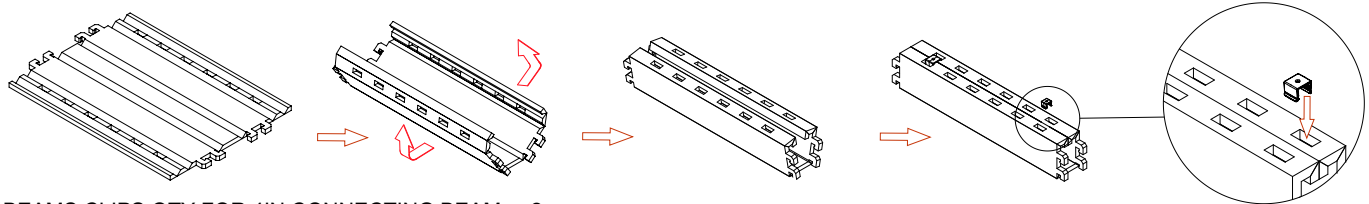

*BEAMS CLIPS QTY FOR 4IN CONNECTING BEAM - x2

FOLD 8IN EXTENTION BEAM AND SECURE IT BY INSERTING BEAMS CLIPS INTO PRE-CUT RECTANGULAR HOLES.

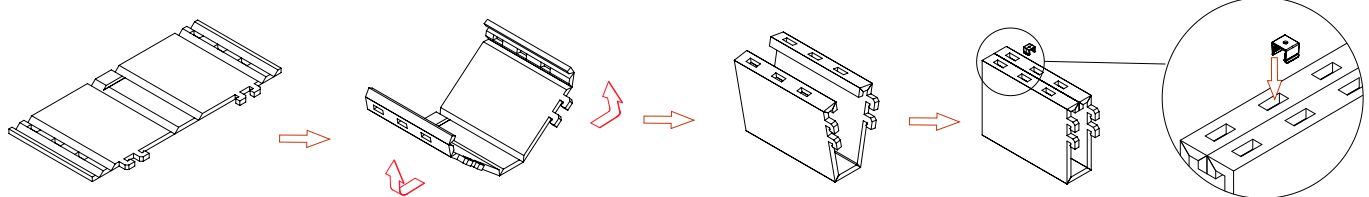

*BEAMS CLIPS QTY FOR 8IN EXTENTION BEAM - x1

*IMPORTANT: DO NOT INSERT CLIPS INTO FIRST AND LAST HOLES OF THE MAIN BEAM

FOLD 8IN CORNER BEAM AND SECURE IT BY INSERTING BEAMS CLIPS INTO PRE-CUT RECTANGULAR HOLES.

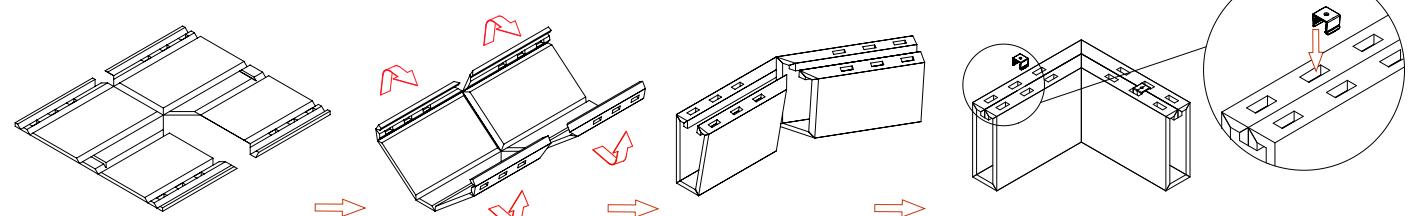

*BEAMS CLIPS QTY FOR 8IN CORNER BEAM - x1

*IMPORTANT: DO NOT INSERT CLIPS INTO FIRST AND LAST HOLES OF THE MAIN BEAM

FOLD 8IN BEAM CONNECTOR AND SECURE IT BY INSERTING INTO PRE-CUT RECTANGULAR HOLES.

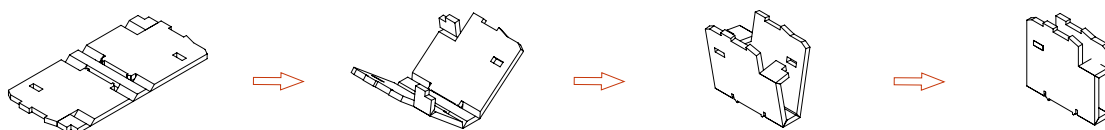

STEP 2

PREPARING 8IN MAIN BEAMS BEFORE ASSEMBLY

DEPENDING ON THE ASSEMBLY DETERMINE HOW MANY BEAMS ARE GOING INSIDE AND HOW MANY OUTSIDE THE ASSEMBLY.

2.1 FOR OUTSIDE BEAMS REMOVE PRE-CUT RECTANGULAR HOLES JUST ON ONE SIDE.

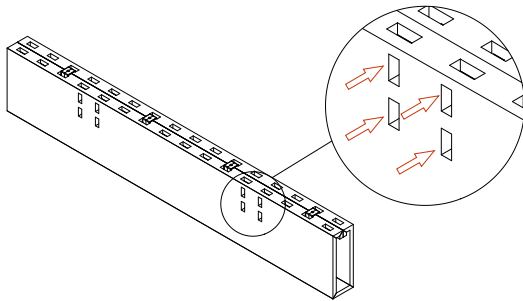

2.2 FOR INSIDE BEAMS REMOVE PRE-CUT RECTANGULAR HOLES ON BOTH SIDES.

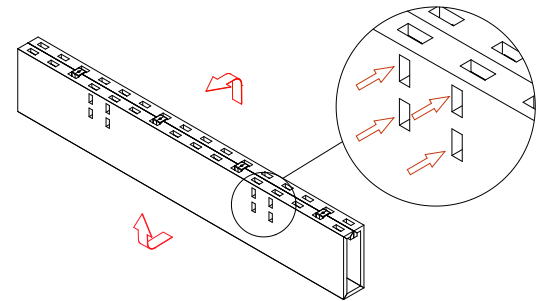

TIP* REMOVE PRE-CUT RECTANGULAR HOLES BY PUSHING THEM INSIDE.

STEP 3

4IN CONNECTING BEAMS INSTALL

3.1 INSERT THE 4IN CONNECTING BEAMS INTO THE CORRESPONDING PRE-CUT RECTANGULAR HOLES IN THE 8IN MAIN BEAM.

3.2 AFTER INSERTING, PUSH 4IN CONNECTING BEAM DOWN TILL YOU HEAR LOCKING SOUND AND TOP SURFACES ARE FLUSH.

3.3 REPEAT STEPS 3.1 - 3.2 FOR EACH 4IN CONNECTING BEAM UNTIL THE ASSEMBLY AS SHOWN HAS BEEN COMPLETED.

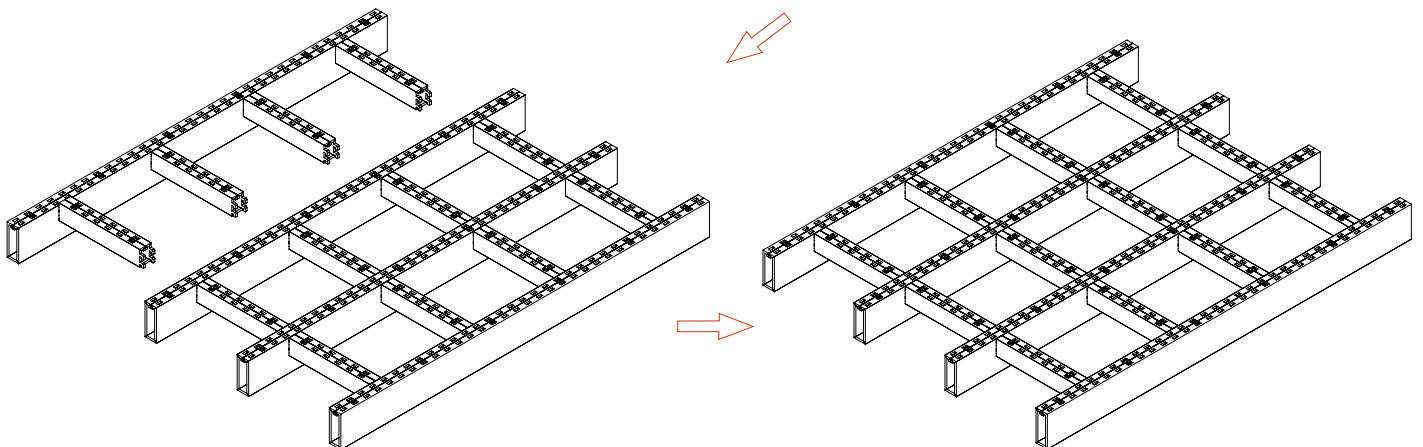
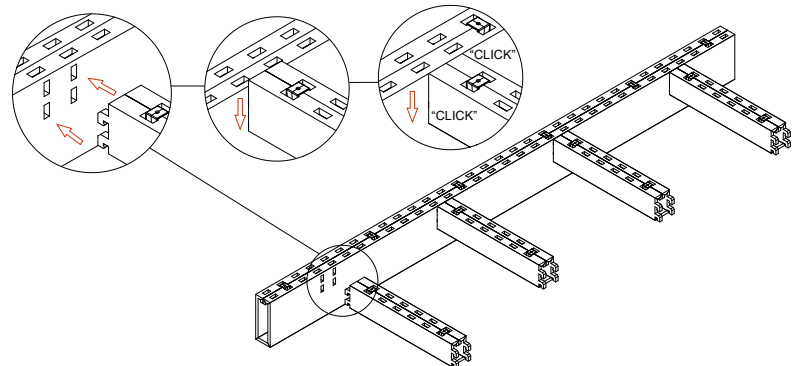

STEP 4

8IN BEAMS CONNECTOR INSTALL

4.1 INSERT 8IN BEAMS CONNECTORS INTO THE ENDS OF 8IN MAIN BEAMS AS SHOWN.

4.2 WITH THE HELP OF FINGER RISE THE TOP OF 8IN MAIN BEAM FOR EASY INSERT.

4.3 INSERT THE 8IN BEAMS CONNECTOR INTO THE CORRESPONDING PRE-CUT RECTANGULAR HOLES IN THE 8IN MAIN BEAM.

4.4 REPEAT STEPS 4.1 - 4.3 FOR EACH 8IN BEAMS CONNECTOR UNTIL THE ASSEMBLY AS SHOWN HAS BEEN COMPLETED.

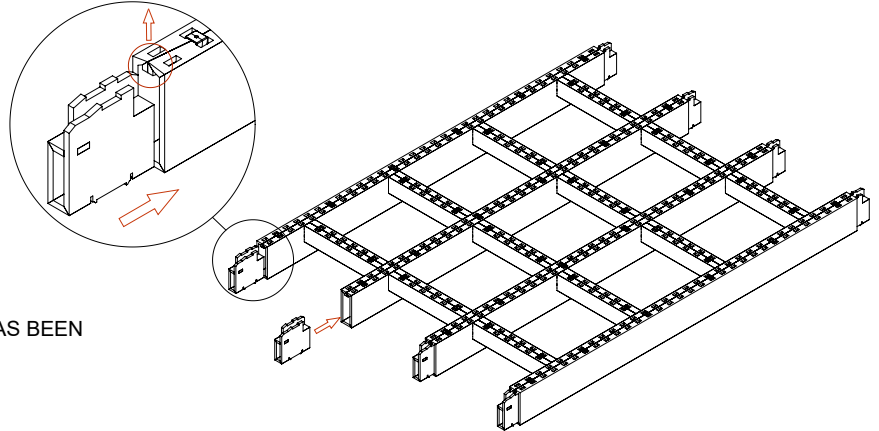

STEP 5

FINISING INSTALL

REPEATING STEPS 3.1 - 4.4 INSTALL REST OF THE PARTS OF THE ASSEMBLY AS SHOWN.

